

## **SWEET SPRINGS MOTORSPORTS COMPLEX (SSMC) - 2022**

### **PURPOSE**

The purpose of the organization is to promote without profit, interest in planning, construction, and racing of modified midgets (micro sprints), in all eligible sanctioned classes. To promote without prejudice or monetary profit, all members of any class of cars.

To promote a fraternal attitude among all members and to all persons engaged or interested in racing. To promote cooperation of all members, and interested persons for the purpose of improving racing, and racing conditions.

To assist members to better understand the principles upon which the organization is based. To assemble, distribute information and data of interest to all members and patrons in order to promote the advancement and protection of the sport of Modified Midget (Micro Sprint) Racing.

The Principle Organization address is:

P.O. Box 68, Sweet Springs, MO., 65351

Regular meetings conducted using parliamentary procedures. Election of officers and board members will be held yearly in December at a time and place designated by the board. The officers of the executive board are comprised of president and vice-president (each serve a two (2) year term with alternating election dates), secretary and treasurer (each serve a one (1) year term with common election date). The seven (7) member board of directors will serve a two (2) year term with alternating election dates (3-4). Paid up members must make all nominations. A board nominee must have been affiliated with the club for three (3) years. A President or Vice President nominee must have at least 1 year of prior Board experience.

The officers of executive board (president, vice-president, secretary and treasurer) are not allowed to vote in matters involving the board of directors. In the event of a vote that has resulted in a tie; the president's vote will be used to break the tie. In order to make a quorum during a board meeting, the Vice President will act as a board member with voting rights.

### **OPERATION**

Sweet Springs Motorsports Complex is operated under club rules of the Mid Missouri Micro Midget Racing Association. Rules requiring a vote shall be passed by a simple majority unless specifically stated otherwise. Only paid club members are allowed voting rights. During racing season, May through September, business is to be conducted under the Board of Directors. No individual club officer, official, or member will be allowed to make a ruling without consent of the majority of the Board, unless their elected position allows them to do so, in a situation at the track that requires immediate attention.

Any promotions, publicity action, concession operations, track improvements, ground improvements, equipment improvements, or any items that raise a cost to the club shall not be allowed without the approval of the board.

Improvements and upkeep of the property grounds and equipment is the responsibility of the club members. If you are asked to help and are capable, you should always be willing to do your share.

**VOLUNTEER!!!**

Mid Missouri Micro Midget Racing Association will operate Sweet Springs Motorsports Complex as long as it remains as a club. If disbandment occurs, the shareholders will take control as they are the primary owners of the property. The future of the facility would be at the discretion of the shareholders. No shares of stock can be claimed for expenses against the facility. The acting president froze sales of the shares when the mortgage for the property was paid in full. Original list of shareholders are primary owners. Release of share sales and price of shares may be made only by a vote of 2/3 majority of entire club.

## PROCEDURES AND GENERAL RULES

### A. Membership and Voting Rights

1. You must have a club membership to have a right to vote on club matters.
2. Dues for voting membership only at the Sweet Springs Motorsports Complex are \$50 annually. Dues for Racing membership at the Sweet Springs Motorsports Complex are \$100 annually, which includes entry in the end-of-the-season points fund.
3. Drivers wanting to participate in any end-of-the-season awards MUST become members on or before His/Her first race.
4. Regular club meetings will have a time limit of two (2) hours. If more time is needed it shall be voted on by the club.

### B. Pit Passes and Entry Fees

1. All car owners, drivers and crew members must purchase a pit pass and sign the register at the pit entrance gate before each M.M.M.M.R.A. program. Drivers are responsible for the proper registration and conduct of their crew.
2. Pit Passes must be worn visible throughout all racing programs until the event is officially over. Anyone found in the pit area without a pass will be removed.
3. General admission for all weekly events will be \$10 for 13 and up, \$5 for 6-12, free for 5 and under. Seniors & Military, \$7  
Family Pack, 2 Adult and up to 3 Children, \$22
4. General admission for special events will be \$15 for 13 and up, \$10 for 6-12, free for 5 and under.
5. Pit Pass fees for weekly shows:
  - Racing Member: car and driver \$35, additional car \$30
  - Regular Pit-pass: \$25
  - Pit-pass for children 5 & under is FREE when accompanied by an adult
6. Spectator Season passes can be purchased for \$125, good for all racing events held throughout the year.
7. Reserved pit parking with electricity is NOT available for 2021. Premier Parking is \$250, other Reserved parking is \$150 annually. Parking holders may allow others to use his or her space by signing a written consent.

### C. Race Program Procedure

1. Events will be conducted under the rules outlined in the M.M.M.M.R.A. and S.S.M.S.C. Rule book. During each race event, the referee is in control of the race proceedings from the drop of the first green flag until all cars are cleared from Tech.
2. All drivers must attend the drivers meeting held before each weekly event. The purpose of the drivers meeting is to explain the race procedures for that night's events, flag signals and so on.
3. TRANSPONDERS are used to score the events at SSMC and must be on the car to race. Transponder must be in a bag (available at the track) and mounted on the Right Rear downtube (suggested mounting between the rear bumper bungs if possible). In the event a transponder is not on the car, or is lost from the car during a race, the car will be disqualified from that race.
4. All cars that run in the Feature Race must have participated in, or attempted to start, at least one (1) other racing event in that class (Heat Race).

5. Cars will assemble in the staging area race ready. Any car(s) not on the track by the time the leader has crossed the start finish line will be moved to the tail of the field. Any car(s) arriving after the field has been aligned in race order and the Yellow light has been turned off by the flagman (Late), will NOT be allowed to enter the track. After the FIRST attempt to start, Late car(s) will be given a DNS.
6. If a car stops on the track BEFORE the yellow light is turned off (signifying "green next time by"), they will NOT lose their starting position. If a car stops on the track AFTER the yellow light is turned off, they will be charged with a Yellow Flag and be moved to the tail of the field. In the event a car drops out or is moved to the rear, after entering the racetrack, cars in the same row as the one that dropped will move forward.
7. ORIGINAL STARTS will be between turns three (3) and four (4). All cars will be side by side and nose to tail. Pole car sets the pace for the start as directed by the officials ("Slow" starts will not be tolerated and will be considered "jumping"). Race starts after the cone. When the initial green is displayed, racing may begin! Any car/cars that jump the start will be moved one row back. If the same car/cars jumps the start twice, that car/cars will then be put to the rear of the field.
8. Spins or tangles occurring in the first lap in any event will call for a New start. Cars dead on the track will restart at the rear of the field in the order they were running. Cars in the same row as the one that dropped will move forward. (see Sect. M)
9. RESTARTS will be single file, nose to tail. Passing will be permitted once you have passed the designated cone in turn 4. Any car/cars that hits the cone, passes before the cone, or goes inside the cone will be charged with one yellow and sent to the rear of the field.
10. On weekly points races, heat race lineups will be set by pill draw. Maximum number of cars in a heat race is 10 (Jr. 8).
11. Heat races will be 10 laps (Jr. 8), and the A-mains will be 30 laps (Jr. 20). A-Main laps can be reduced based on car count (30/25/20, Jr. 20/17/13) B-Main laps will be at the discretion of the referee, minimum 1 lap per car, but no more than 20 laps.

FEATURE EVENTS (A, B, C, etc) will have a time limit of 1 minute per lap (eg. 30 laps=30 minute limit). At the end of the time limit drivers will be notified by Raceceiver there are 5 laps left. If a caution occurs after the time limit, drivers will be given Green-White Checker. If another caution occurs, drivers will be given White-Checker. Clock will stop on Red Flag or as determined by race director. Drivers refusing to line up correctly will receive the Black Flag.

12. Feature qualifiers will be determined using the ASCS passing points scale in the heat races. (see table in Section D). The top 20 in heat race points will qualify for A-Feature, the remaining 4 spots will be filled from the B- Main in their finish order. A-Feature starting positions will be aligned by a dice roll determining the number of cars inverted. Jr & Restrictor classes will use 1 die (1-6 cars, a roll of 1 will result in 0 cars inverted). All other classes will use 2 dice (2-12 cars).
13. In the event of a RED FLAG, the ambulance (if needed) will enter the track. Drivers must provide a clear path for the ambulance. The Flagman (with a second from the Infield Steward) may waive off the ambulance at their discretion.
14. The top 5 feature finishers in each class may be impounded following the A-main for technical inspection. The only persons allowed in tech area are the driver of the car and one (1) crew member of that car.
15. No two-way radio communications are allowed between the driver & the pits. RACECEIVERS are required. Car re-alignment will be a combination of Raceceiver Communication, Hand Signals & Lineup board. Racers not in position after 2 laps will be sent to the tail of the field. Further refusal to "get in line" will result in a Black Flag.

## D. Point System

1. You must have 10 weekly races in order to qualify for the end-of-the-year point fund.
2. Only the top 13 weekly shows will be counted toward the driver's yearly total. Season Championship total will be based on Feature points only. No points awarded for Heat Races and No Passing Points will be counted.
3. Drivers cannot have more than 3 races in any prior season in the same class to be considered a Rookie in that class. Rookie candidates must register with SSMC to qualify for yearend honors.
4. If a driver is disqualified from the main event, all points accumulated for that night will be lost.
5. A DQ due to a Class B Tech Violation cannot be used as one of the 10 qualifying races or as one of the 13 weekly races in the yearly points total. A DQ (Class B Tech Violation) is the same as not attending the race (See TECH RULES, VIOLATIONS & PENALTIES Section J.1.b.)
6. If a driver chooses to "pull tail", passing points will be awarded from the original scheduled starting position.

## POINT DISTRIBUTION SYSTEM

### ASCS Passing Point Scale

	<u>Start</u>												
		<u>1</u>	<u>2</u>	<u>3</u>	<u>4</u>	<u>5</u>	<u>6</u>	<u>7</u>	<u>8</u>	<u>9</u>	<u>10</u>	<u>11</u>	<u>12</u>
	<u>1</u>	<b>100.0</b>	105.0	110.0	115.0	120.0	125.0	130.0	135.0	140.0	145.0	150.0	155.0
	<u>2</u>	91.5	<b>93.0</b>	98.0	103.0	108.0	113.0	118.0	123.0	128.0	133.0	138.0	143.0
	<u>3</u>	83.0	84.5	<b>86.0</b>	91.0	96.0	101.0	106.0	111.0	116.0	121.0	126.0	131.0
	<u>4</u>	74.5	76.0	77.5	<b>79.0</b>	84.0	89.0	94.0	99.0	104.0	109.0	114.0	119.0
<b>Finish</b>	<u>5</u>	66.0	67.5	69.0	70.5	<b>72.0</b>	77.0	82.0	87.0	92.0	97.0	102.0	107.0
	<u>6</u>	57.5	59.0	60.5	62.0	63.5	<b>65.0</b>	70.0	75.0	80.0	85.0	90.0	95.0
	<u>7</u>	49.0	50.5	52.0	53.5	55.0	56.5	<b>58.0</b>	63.0	68.0	73.0	78.0	83.0
	<u>8</u>	40.5	42.0	43.5	45.0	46.5	48.0	49.5	<b>51.0</b>	56.0	61.0	66.0	71.0
	<u>9</u>	32.0	33.5	35.0	36.5	38.0	39.5	41.0	42.5	<b>44.0</b>	49.0	54.0	59.0
	<u>10</u>	23.5	25.0	26.5	28.0	29.5	31.0	32.5	34.0	35.5	<b>37.0</b>	42.0	47.0
	<u>11</u>	15.0	16.5	18.0	19.5	21.0	22.5	24.0	25.5	27.0	28.5	<b>30.0</b>	35.0
	<u>12</u>	6.5	8.0	9.5	11.0	12.5	14.0	15.5	17.0	18.5	20.0	21.5	<b>23.0</b>

### A FEATURE POINTS

1st	<b>300</b>	9th	<b>226</b>	17th	<b>192</b>
2nd	<b>284</b>	10th	<b>220</b>	18th	<b>188</b>
3rd	<b>270</b>	11th	<b>216</b>	19th	<b>184</b>
4th	<b>260</b>	12th	<b>212</b>	20th	<b>180</b>
5th	<b>250</b>	13th	<b>208</b>	21st	<b>178</b>
6th	<b>244</b>	14th	<b>204</b>	22nd	<b>176</b>
7th	<b>238</b>	15th	<b>200</b>	23rd	<b>174</b>
8th	<b>232</b>	16th	<b>196</b>	24th	<b>172</b>

## **E. Safety & Conduct**

1. Children are allowed in the pit area but parents must fill out insurance and waiver release and must be notarized before the child is allowed entrance. These forms are available in the sign in shack. All drivers under the age of 18 must have a valid birth certificate copy at the time of registration. A parent and/or legal guardian must accompany minors in the pit area.
2. Proper conduct is expected of all people in and around the track and pit area. Any person, driver, crew or otherwise continually harassing an official or other patrons will be removed from the premises.
3. No verbal confrontations allowed.
4. Any obscene gestures from drivers or members of pit crews to anyone will result in a one (1) week suspension. Additional offenses will be dealt with by the Board of Directors. Zero Tolerance Rule.
5. Paybacks on the racetrack will result in a disqualification by the flagman. There will be Zero Tolerance on and off the racetrack.

## **F. Track Rules and Interpretation**

1. All competitors will be required to follow all rules set down by the M.M.M.R.A. and SSMC.
2. Owners & Drivers are responsible for the actions of the persons in their pit area, including, but not limited to, family members, pit crews and guests.
3. Absolutely NO ALCOHOL shall be consumed in the pit area during a race event.
4. The Board of Directors shall, if requested, interpret any procedure or rule herein. Questions concerning the meaning of these rules shall be directed to the Board of Directors.
5. The Board of Directors will determine track preparations. Anyone complaining about track preparation may be disqualified for the night's event.
6. Anyone serving a suspension will not be allowed to participate or serve in any capacity at the facility.

### **ATV & Pit Vehicle Use**

1. All ATV's & Pit Vehicles MUST be insured & registered with the MMMMRA (proof of insurance is required at time of registration).
2. Only one ATV allowed per registered car.
3. Registration can be revoked at any time due to misconduct.
4. Racetrack insurance does not cover ATV accidents.
5. All ATV's will be used for race related activity only.
6. No one under 16 years will operate the ATV.
7. No riders allowed on ATV's.
8. After all races, all ATV's must be put away.
9. 10 MPH SPEED LIMIT!!
10. No tolerance – you will be requested to put ATV away immediately.
11. No scooters, or skateboards.
12. Rules apply to the ATV (not the rider)

\*\*\*\*\* The Sheriff will be called and you will be removed from the property if ATV rules are not followed.

## **G. Club Notes**

1. Members of the Mid Missouri Micro Midget Racing Association (MMMMRA) support Sweet Springs Motorsports Complex (SSMC). Members are encouraged to participate through club meetings, workdays and club sponsored fundraisers.
2. Track billboards are available for a first-year fee of \$300 and an annual renewal fee of \$150.
3. Minor racing members may be refused permission to compete in a race where a contract or state law prohibits minors from competing on the premises. M.M.M.M.R.A. will set the minimum age for their track subject to state law and insurance carrier. All crew members will sign in under a respective car number. Car's Owners &/or Driver will be responsible for such persons signed in under their car number. Before a Racing Membership can be granted, all applicants under age 18 must have a notarized minor release form on file. A copy of birth certificate must accompany all new applications for this age group.
4. Any proven false statements made on any document issued to, or concerning the M.M.M.M.R.A. by any member, shall draw penalties as the Board of Directors may deem proper.
5. Female drivers will not be allowed to participate in sanctioned competition while they are pregnant. Any female driver who knowingly competes in an M.M.M.M.R.A. race while pregnant will automatically be disqualified from participating in M.M.M.M.R.A. insurance benefits.

## **H. Rule Change Procedure**

1. A CLASS Rules Committee will be appointed to a 1-year term by the Board of Directors. The committee will be comprised of board appointed "Class Representatives", one from each class, and the current sitting board.
2. Rule Proposals should be clearly printed or typed on the Rule Proposal Form available from the club Secretary and posted on the SSMC website. Rule Proposals must be submitted by the deadlines listed (maximum of 2 rule proposals per Club Member).
  - a. CLASS Rules: Submitted by August 1, Final decision by November 1.
    - i. Major Engine Rules (i.e. Displacement/Bore & Stroke) will only be considered in November of even number years (i.e. 2022). Any approved Major Engine Rule change would become effective at the start of the following even year racing season (i.e. 2024).
  - b. Procedures & General Rules: Submitted by January Club meeting, Decided at February Club meeting.
3. The CLASS Rules Committee will consolidate the CLASS Rules proposals and meet to validate, review, edit, discuss and vote on all valid proposals ("Class Representatives" should meet with their class racers to discuss the CLASS Rules proposals prior to submitting to the committee). CLASS Rules proposals deemed worthy by committee vote will be presented to the general membership by the committee chairman for discussion. The results of the committee vote and general membership discussion will not be final, as the Board of Directors will meet on or before November 1 to achieve a final ruling on any and all proposals.
4. The Board of Directors may take immediate action on "Emergency Rules Situations" without a Rule Proposal if such an emergency is deemed necessary to the interest and welfare of the club.

## I. COMPETITION RULINGS

1. On arrival at the track, signing in must be the first thing done to insure proper insurance coverage.
2. No refund allowed after sign in without board approval.
3. Switching of drivers after Heat Race must be reported to judges in charge of scoring, any driver not doing so will be disqualified for the event. Substitute drivers will start at the tail of the event the CAR was qualified for.
4. Wings, if required by class rules, will be mandatory to enter the night's event. Only exception will be in case of a rollover, a car can finish the night without a wing if a backup is not available. It is recommended for top wings to be pinned for easy removal in case of driver injury.
5. Cars re-entering the race from the infield (under Green Flag Conditions) must do so on the front or backstretch. They must have all four tires on the racing surface before the start/finish line to be scored for that lap. Cars must be started and running in the infield before entering the track area. The race must not be allowed to continue as long as a car is dead on the track. Cars that leave the track and enter the pits will not be allowed to continue the race. When a car enters the track surface for a race, it may not go back to the pits and re-enter again for that race.
6. ROUGH DRIVING WILL NOT BE TOLERATED, and drivers will be given the Black Flag and may be subject to a fine or suspension from racing.
7. The end of a race will be official when the lead car receives the Checkered Flag, regardless of how many laps the following cars have completed. Finish positions will be determined in the order by which the cars complete the scheduled distance of the race. Cars unable to complete the scheduled distance will be scored by the number of laps completed. Cars involved in spins or tangles after the Checkered Flag falls, which are able to continue under their own power, will be scored in the order they cross the start/finish line.
8. All cars must cross the finish line under their own power.
9. When entering or leaving pit, Driver must use due caution!
10. From the start of a race to the Checkered Flag, the flagman controls the event. All drivers must watch and obey the flagmen.
11. ALL Reds will be CLOSED and a WORK AREA will be available at the exit of the track between the wall and the concrete barriers. If repairs can be made to the car(s) while in that area, those repairs will be allowed. Cars may not be taken to the trailer and the races will not be held for cars being repaired. Once the officials have given the "all clear", the yellow light will be displayed and race proceedings will resume. If repairs are completed and the car has re-entered the track before the yellow light is turned off (signifying "green next time by") the car(s) will be allowed to re-enter and get in line at the tail. Work may continue until a racing lap has been completed. If a yellow is displayed before a lap has been completed, the car will be allowed to re-enter at the tail if repairs are complete.
12. Entering or Crossing the racetrack is NOT allowed except on an OPEN Red (this includes, but is not limited to, people, tools, parts, tires, fuel & supplies). Exiting the infield under Yellow or Red flag conditions is allowed when following/escorting a disabled car.
13. During feature events, 1 crewman per race car is allowed in the infield with parts & supplies (no motorized vehicles or motorized carts allowed). If a racer enters the Infield or Hot Pit under a YELLOW or a RED, he will lose his racing position and be sent to the tail on the restart.

## **J. TECH RULES, VIOLATIONS & PENALTIES**

1. Tech inspection will occur after each feature event as a Random Selection (Spin Wheel or Randomizer App) from a specific list of posted items for Each Class (Fuel will be subject to inspection at any time). The random selection should be conducted in the presence of the Top 3 finishers if possible. Additional Tech Inspection may also be conducted at the discretion of the Tech official and can also occur by individual protest (see Section L).

Penalties will be as follows:

- a. Class A Violation: Car setup, Weight

Loss of points that event (heat or feature) only. If Violation occurs during feature event, car will be issued a DQ and will not receive points or pay for that night's race.

- b. Class B Violation: Engine, Fuel, Performance (Includes Tire Prep/Dope)

Penalties for anyone caught cheating (engine, fuel, ignitions, performance or Tire Prep/Dope) will be as follows: (suspensions include special races)

- i. 1<sup>st</sup> Offense or First TECH Refusal: \$250 fine, DQ from race, loss of pay, and disqualification from the points fund for that season.
- ii. 2<sup>nd</sup> Offense or Second TECH Refusal: \$500 fine, DQ from race, loss of pay, 2-week suspension and disqualification from the points fund for that season.
- iii. 3<sup>rd</sup> Offense or Third TECH Refusal: \$1000 fine, DQ from race, loss of pay, 1-year suspension and disqualification from the points fund for that season.

- c. Payment of fines must be made in full before the car, driver or owner can compete in any activities.
- d. Fees from all fines will be placed in the club general fund.
- e. Any item or component resulting in a Class B Violation will have to be re-verified before the car is allowed to resume competition at SSMC.

## **K. SAFETY REGULATIONS**

1. The ambulance or emergency vehicle must be present before any cars are allowed on the track.
2. At least two (2) fire extinguishers (Purple K) must be within the confines of the track during testing periods and racing. Two (2) additional fire extinguishers will be made available in the pits. One (1) fire extinguisher will be in the authorized push vehicle at all times.
3. It is recommended to install a cross brace back of the seat to support the shoulder harness. (See *Figure 3 at end of Rule Book*)
4. Any car that upsets or rolls over on its side may be allowed to continue at official's decision. Any driver requiring medical attention as a result of an accident while participating in a race must obtain a written release from the attending physician before being allowed to race again.
5. Any driver involved in an accident may be disqualified for the remainder of the night, if, in the opinion of the medical staff, it is inadvisable for him/her to continue.

## **L. PROTESTS & FEES**

1. Protests for technical infractions must be submitted to the Referee in written form within 30 minutes of the posted finish of the last event.



2. ENGINE: Engine Protest fee is \$500. An engine protest will involve removal of the engine by the owner for presentation to the Tech Official at the track, removal of the oil pan to verify crankshaft and connecting rods, removal and verification of the cylinder head, measurement of bore & stroke and verification of pistons, camshafts & camshaft timing. The Official Inspector involved will be paid \$100 of the protest fee. If legal, \$400 goes to the protested party. If illegal, \$400 is returned to the protesting party.
3. Any other technical protest, including fuel, will require a \$150 fee be paid by the protesting party. The Official Inspector involved will be paid \$30 of the protest fee. If legal, \$120 goes to the protested party. If illegal, \$120 is returned to the protesting party.
4. Penalties resulting from a protest will be as outlined in Tech Rules, Violations & Penalties section.

## M. FLAG SIGNALS

Warning lights are to be considered the same as a yellow flag. Violation of any flag signal will bring a disqualification.

THE FLAGS OR LIGHTS ARE OFFICIAL AT ANY POINT DISPLAYED.

**GREEN:** Starting the Race.

**YELLOW:** Caution.

No passing. DO NOT RACE BACK TO THE STARTING LINE ON A YELLOW FLAG CONDITION. Slow to parade speed immediately, hold your position and line up single file with space to allow track officials to re-order cars as necessary. **All cars dead on the track will restart in the rear in the order they were running. Car or cars that start the reason for the yellow flag will also go to the rear and be placed in the last starting position for causing the yellow flag.** Any car with more than 1 unassisted ("charged") Yellow Flag will be eliminated from the remainder of the race. There will be no working on cars on the track surface. Any car that stops on the track surface during a race (unless directed to do so by a track official) will go the rear of field.

**RED:** Stop at Once.

Any accident occurring after the first lap has been completed and it is necessary to stop the race, the cars will be re-started in the order they finished the lap previous to the accident in single file. All cars dead on the track will restart in the rear in the order they were running if the track officials consider the cars safe to start. If the race has gone 2/3 or more and in the opinion of the Flagman it is unsafe or unwise to continue, positions will be awarded in the order that the cars would have been restarted.

**WHITE:** One lap to finish.

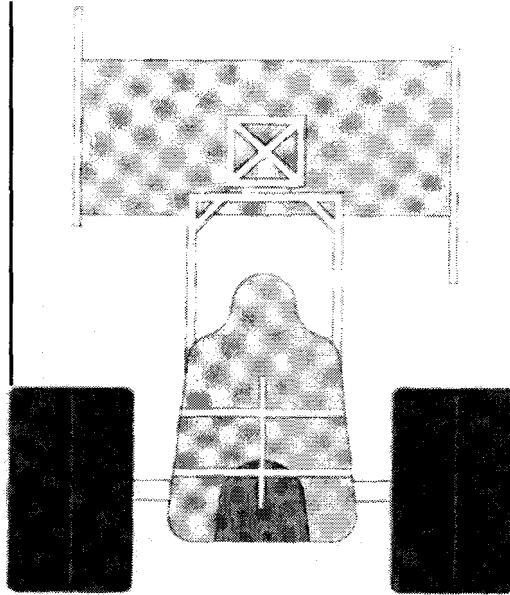
**BLACK:** Report to infield immediately.

**CHECKERED:** Race is complete and final.

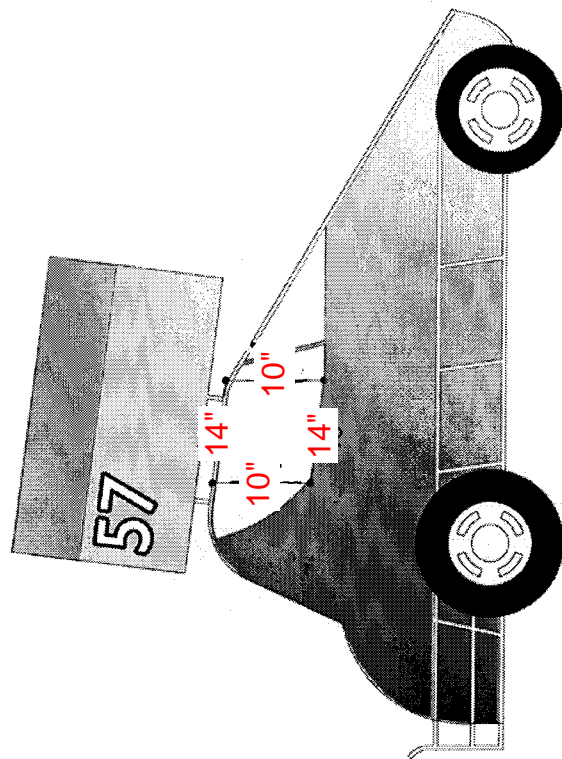
Richard Kreisel  
04/01/22

Rev. 1 – Revised board member election & terms, Clarified Referee period of control - 12/08/14  
Rev. 2 – Clarified penalty for late arriving cars – 02/27/15  
Rev. 3 – Revised Raceceiver requirements – 03/13/15  
Rev. 4 – Revised Section C. Race Program Procedure – 07/19/15  
Rev. 5 – Revised Section H.2.a. Rule Change Procedure – 10/27/15  
Rev. 6 – Added Clarifications to Sections C, I, J & L – 11/23/15  
Rev. 7 – Revised Spin Rule & Raceceiver requirements – 03/01/16  
Rev. 8 – Revised Electrical Parking price – 10/26/16  
Rev. 9 – Added Hot Pit & Changed Restarts for JR Class – 02/20/17  
Rev. 10- VP act as board member to make a quorum, ASCS Lineup & Point System – 03/01/2018  
Rev. 11- Changed Heat Lineup and Points, increased entry fees – 04/22/2019  
Rev. 12- Revised Major Engine Change to Even Years, Added Time Limit, Increased penalty for Violations – 03/31/20  
Rev. 13- Corrected Officer Terms – 01/27/21  
Rev. 14- Changed Feature Lineup and Points, included Premier Class Payout – 03/05/21  
Rev. 15- Revised Pres. & VP qualifications (1 yr on board), Changed Lineup Procedure ASCS w/ dice roll – 04/01/22

Wing must be within these boundaries.

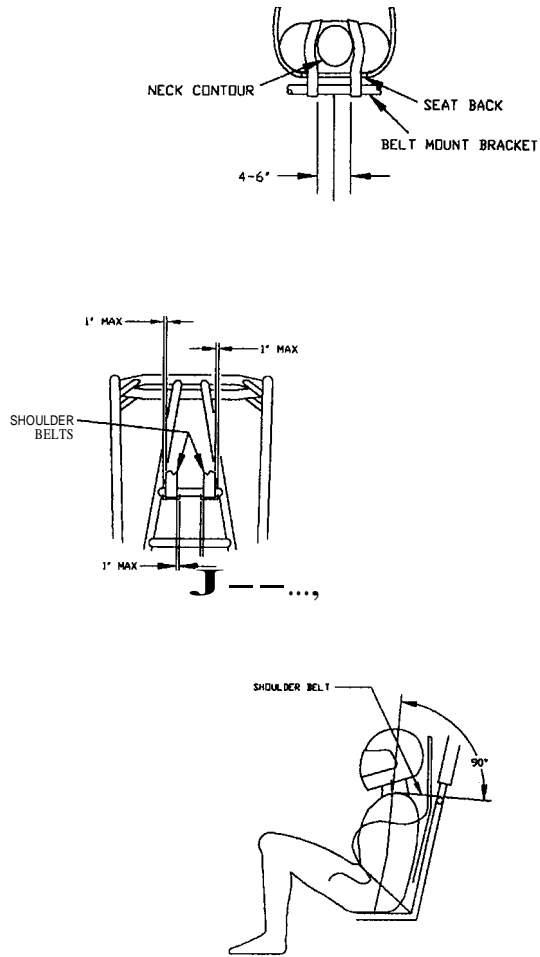


**Figure 1**



**Figure 2**

Rev. 1 - Side Opening size revised to 10" x 14" - 05/08/14



**Figure 3**